

CV6XX-DH

Outdoor Dome Housing



*Camera not included

Installation Instructions

Optional Weather Power Supply [CV-H20-PWR](#)











The CV-H20-PWR is highly recommended for use with this product



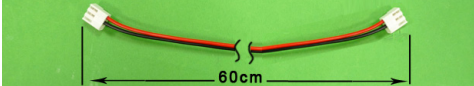

Table of Contents



- 1. Warning 03
- 2. Installation Instructions 04
- 3. Assembly of Cables 05
- 4. Wall Mount Bracket and Dome Housing Installation 06
- 5. Appendix 09
- Safeguards 10
- Warranty 11

1. Warning

 WARNING	
 	<p>WARNING</p> <p>To reduce the risks of an electric shock, do not expose inside of this unit to rain or moisture.</p> <p>Installation on a rainy day may also cause fog around the capsule.</p>
	<p>Installation</p> <p>Installation should be done by qualified installer only and should conform to all local codes.</p>
	<p>Ensure strength of Supporting Dome Housing Unit</p> <p>The unit must be properly and securely mounted to a supporting structure capable of sustaining the weight of the unit. Recommend use 3/8" stainless screws x four (4).</p>
	<p>Do Not Change or Modify</p> <p>You are cautioned that any changes or modifications not expressly informed by these instructions could void your warranty and ability to properly operate this equipment.</p>
	<p>Basic Operating Environment Conditions</p> <p>This product is designed to function under normal outdoor -20°C (-4°F) ~ +50°C (122°F) conditions. Operation in constant high temperatures over +50°C (122°F) and over 90% humidity is not advised, and may void your warranty.</p> <p>For use in conditions -20°C (-4°F) or below, it is recommended to install an additional heater and +50°C (122°F) or above it is recommended to install two fans and a sunshield.</p> <p>Operating temperature and humidity of camera varies from camera to camera. For use with non-Marshall cameras, check with the manufacturer prior to use.</p>
	<p>Fasten wires tightly.</p> <p>Attention:</p> <p>Please keep any loose wires away from the fan or heater.</p>

2. Installation Instructions

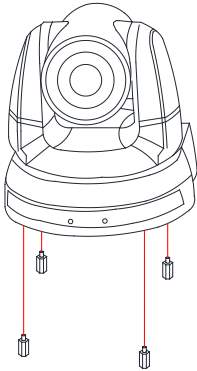
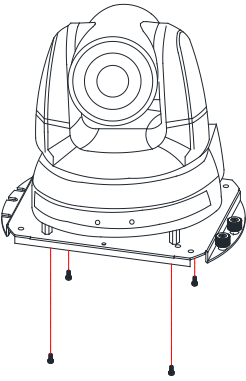
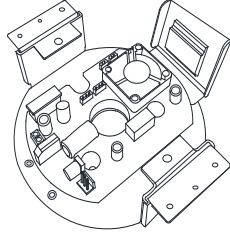
 WARNING		Fasten wires tightly Attention: Please keep loose wires away from the fan or heater
	Cables	
	L605-1	
		Power cable to PC board
	L704P-1.0	
		Power cable to camera (1.0mm DC Plug)

Installation of camera and mounting plate		Assembly of the Cables	
			
Tighten hexagonal spacers x 4 on the camera.	Tighten M4x10 double washer screws x 4 to fix the hexagonal spacers to the mounting plate.	Connect L605-1 and L704P-1.0 to the PC board.	Connect L704P-1.0 to the camera.

3. Assembly of Cables

1. DC 12V FAN
2. AC 24V HEATER
3. HEAT SENSOR
4. DC 12V OUT
5. AC 24V OUT
6. AC 24V IN

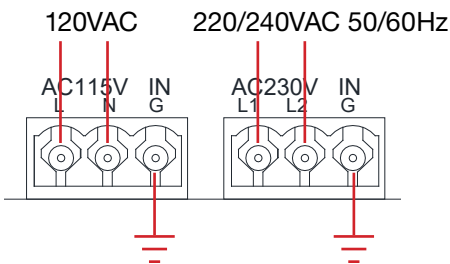
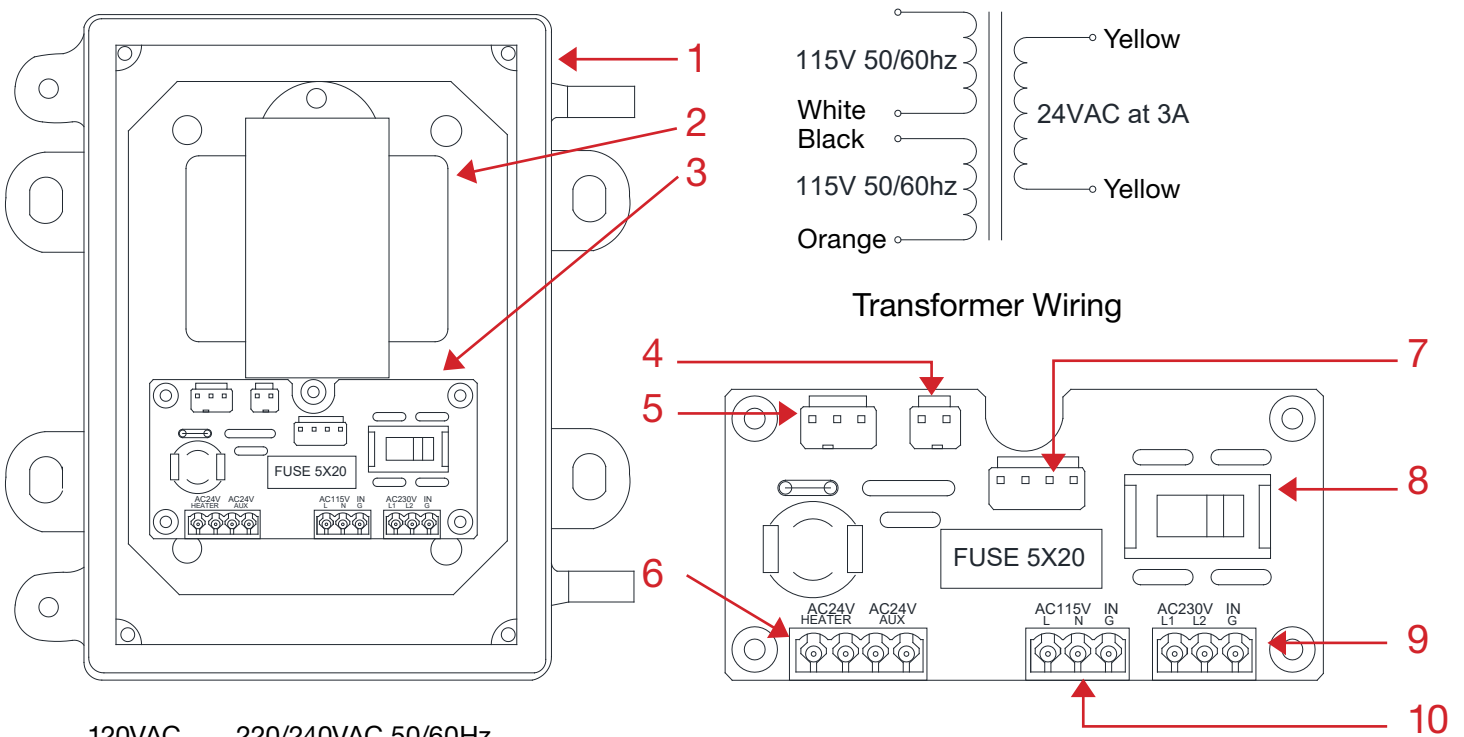
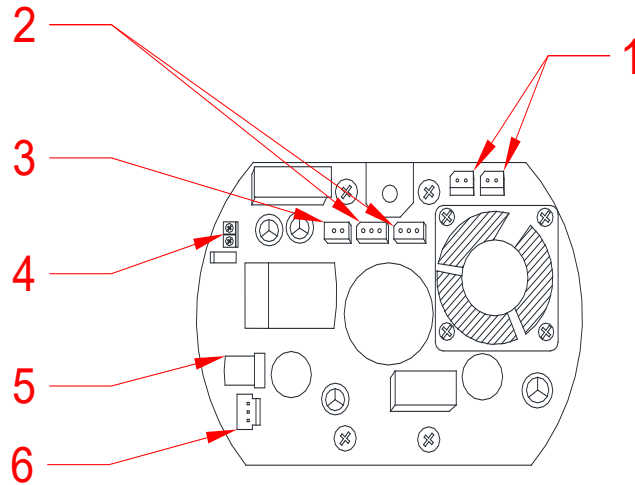

Part Description		Part Description	
1	Power Box	6	24VAC heater & AUX
2	Transformer	7	115/230V to Transformer
3	PS-2430.0	8	115/230 VAC Switch
4	24VAC from Transformer	9	AC230V IN
5	24VAC Out to Housing	10	AC115V IN

4. Wall Mount Bracket and Dome Housing Installation

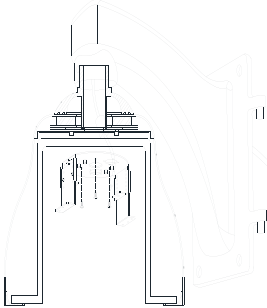
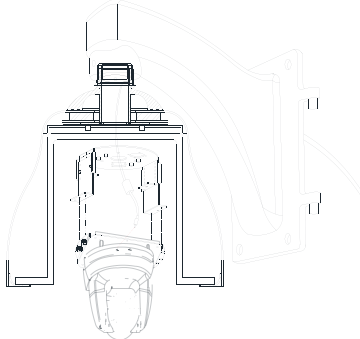
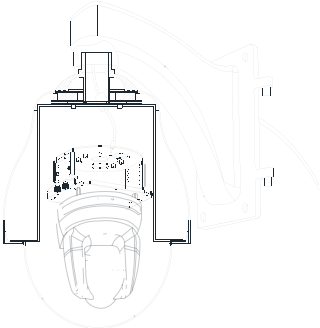
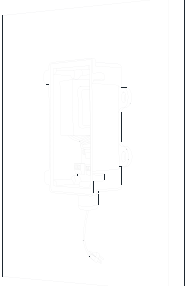
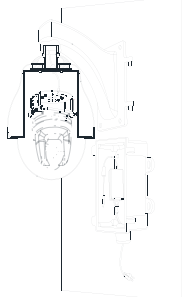
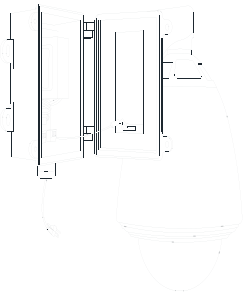
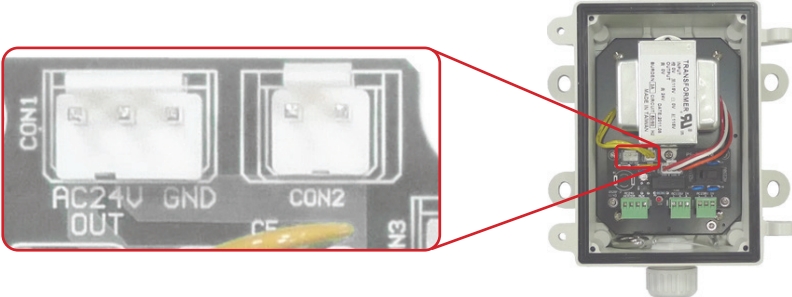
 <p>2-1 Insert cables through the bracket.</p>	 <p>2-2 Assemble the dome housing and bracket.</p>	 <p>2-3 Fix camera to dome housing and connect the cables.</p>
 <p>2-4 Use M5 nut to fix cover and dome housing.</p>	 <p>2-5 Attach the power box to the wall or to the column.</p>	 <p>2-6 Connect bracket arm to the power box.</p>
 <p>2-7 Attach safety cable and connect cables from box and camera dome.</p>	 <p>2-8 Connect L605-1 power cable to part no. 5 of PS-2430 circuit board in the power block unit.</p>	

2-9-1

Insert the power cables for the 220~240VAC or 110~120VAC power supply input through the weatherproof cable holes located below the power block unit and connect the power cables for the 220~240VAC or 110~120VAC power supply input to the PS-2430 circuit board to the power block unit. Please refer to 14-2 for 220~240VAC power input connection and 14-3 for 110~120VAC VAC Power input connection.



DANGER! Please make sure the AC power plug is not plugged into 3 pin power socket before performing Installation Step 2-9-2 and 2-9-3.

For 220~240VAC Pwr Input Connection

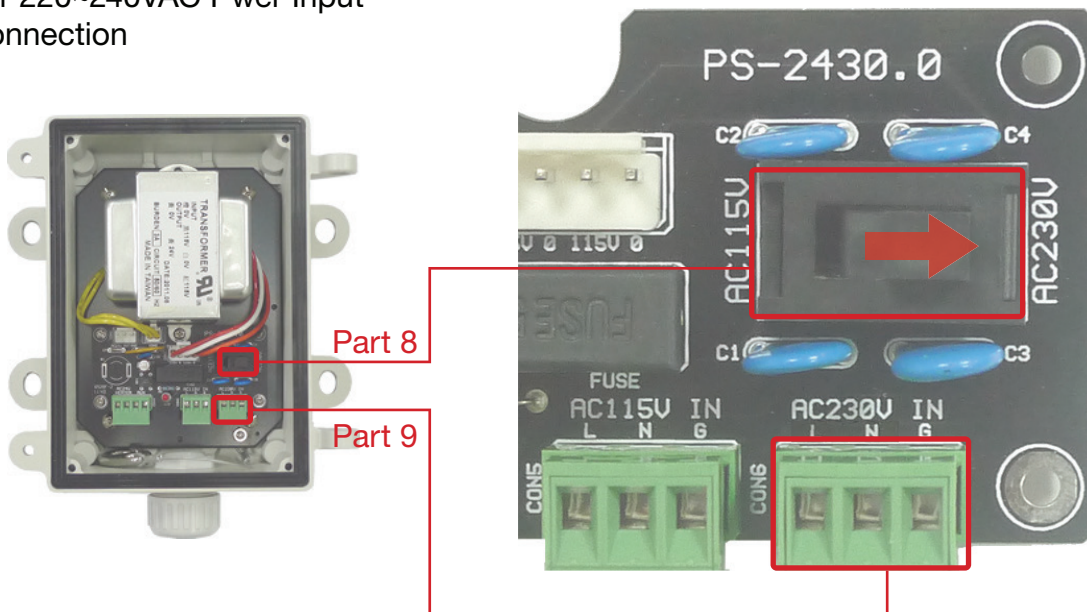

2-9-2

For 220~240VAC Power input connection, connect L(Live), N(Neutral), and G(Ground) power wires to corresponding screw terminal of AC230V POWER INPUT (part 9) on the PS-2430 circuit board, and turn switch (part no. 8) on the PS-2430 circuit board to AC230V.

For 110~120 VAC Power Input Connection

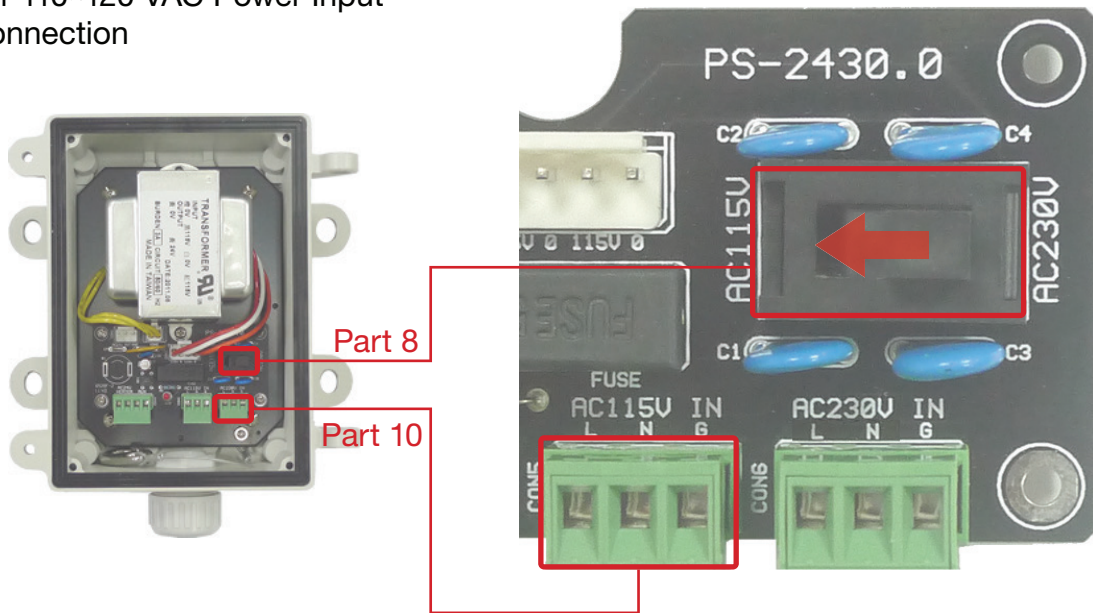

2-9-3

For 110~120VAC VAC Power input connection, connect L(Live), N(Neutral), and G(Ground) power wires to corresponding screw terminal of AC115V POWER INPUT (part no. 10) on the PS-2430 circuit board, and turn switch(part no.8) on the PS-2430 circuit board to AC115V.

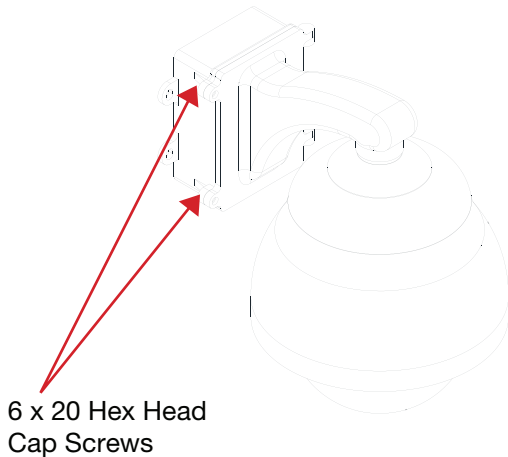

2-10

Fix bracket and power block unit with two 6 x 20 hex head cap screws.
Installation of the CV6XX-DH is now complete.

Note:

User only needs to do connections for part 5, 9 or 10 on the PS-2430 circuit board for the power block unit.

For one heater, total power is 3A (around 72W), fan and heater consume around 25W.

After fan and heater hooked up and working, there is 47W power available for camera.

* It is advisable to use two heaters in areas which reach below -25°C. For two heaters, total power is 3A (around 72W), fans and heater consume around 45W. After fan and heater hooked up and working, there is 27W power available for camera.

5. Appendix

Dimensions

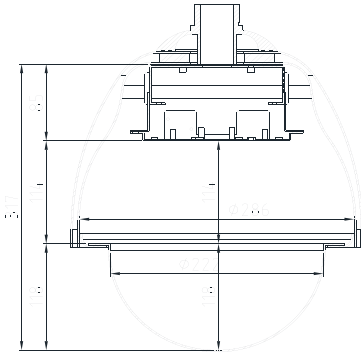

9" housing

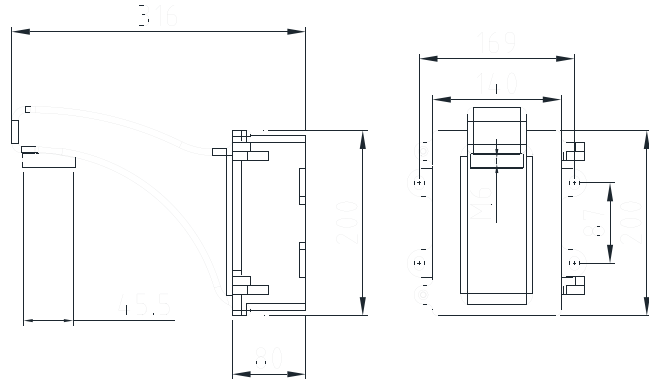

Wall mount bracket with power box

Component Parts for Assembly



Hexagonal spacers x 4



M4 x 10 double washer screws

Screws Mounting Position

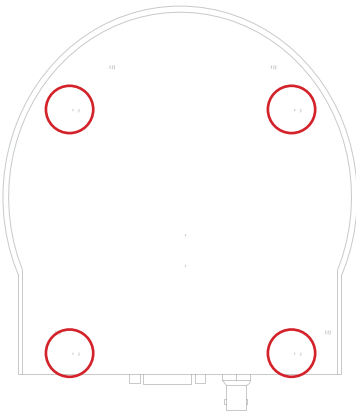

Position of screw holes on the camera for fixing hexagonal spacers.

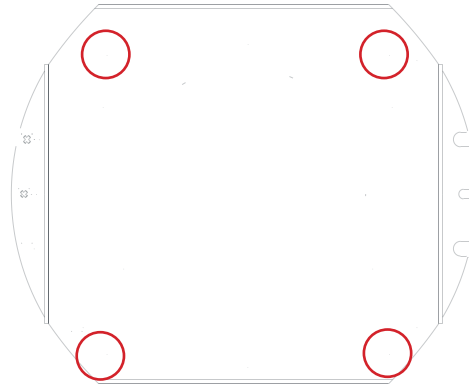

Position of screw holes on the mounting plate for fixing hexagonal spacers.

Installation Steps

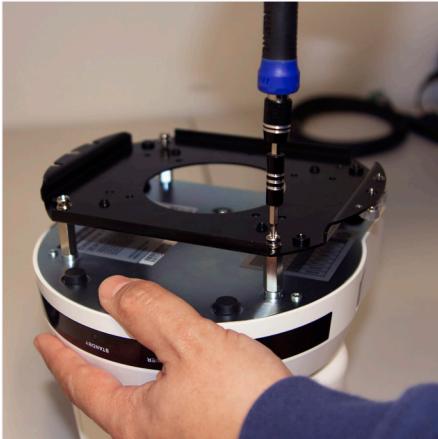
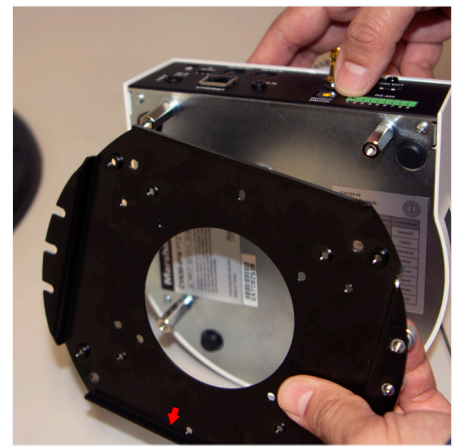

IMPORTANT SAFEGUARDS

1. **Read Instructions** – All the safety and operating instructions should be read before operating the unit.
2. **Retain Instructions** – The safety and operating instructions should be retained for future reference.
3. **Heed Warnings** – All warnings on the unit and in the operating instructions should be adhered to.
4. **Follow Instructions** – All operating user instructions should be followed.
5. **Electrical Connections** – Only a qualified electrician should make the electrical connections.
6. **Attachments** – Do not use attachments not recommended by the product manufacturer as they may cause hazards.
7. **Cable Runs** – All cable runs must be within permissible distance.
8. **Mounting** – This unit must be properly and securely mounted to a supporting structure capable of sustaining the weight of the unit. Accordingly:
 - a. The installation should be made by a qualified installer.
 - b. The installation should be in compliance with local codes.
 - c. Care should be exercised to select suitable hardware to install the unit, taking into account both the composition of the mounting surface and the weight of the unit. Be sure to periodically examine the unit and the supporting structure to make sure that the integrity of the installation is intact. Failure to comply with the foregoing could result in the unit separating from the support structure and falling, with resultant damages or injury to anyone or anything struck by the falling unit.

SAFETY PRECAUTIONS



CAUTION
RISK OF
ELECTRIC SHOCK!



**CAUTION: TO REDUCE THE RISK OF
ELECTRICAL SHOCK, DO NOT EXPOSE
COMPONENTS TO WATER OR MOISTURE.**



The lightning flash with an arrowhead symbol, within an equilateral triangle, is intended to alert the user to the presence of non-insulated “dangerous voltage” within the product’s enclosure that may be of sufficient magnitude to constitute a risk of electric shock to persons.



The exclamation point within an equilateral triangle is intended to alert the user to the presence of important operating and maintenance (servicing) instructions in the literature accompanying the appliance.

UNPACKING

Unpack carefully. Electric components can be damaged if improperly handled or dropped. If any of the products appear to have been damaged during the shipment, replace it properly in its carton and notify the shipper.

Be sure to save:

1. The shipping carton and packaging material. They are the safest material in which to make future shipments of the equipment
2. The Installation and Operating Instructions.

SERVICE

If the product needs repair service, the customer should contact Marshall Electronics, Inc. for instruction and authorization to return the products for service.

TECHNICAL SUPPORT

If technical support is needed, please contact:

support@marshall-usa.com

(800) 800-6608

Warranty

Marshall Electronics warranties to the first consumer that this device will, under normal use, be free from defects in workmanship and materials, when received in its original container, for a period of two years from the purchase date. This warranty is extended to the first consumer only, and proof of purchase is necessary to honor the warranty. If there is no proof of purchase provided with a warranty claim, Marshall Electronics reserves the right not to honor the warranty set forth above. Therefore, labor and parts may be charged to the consumer. This warranty does not apply to the product exterior or cosmetics. Misuse, abnormal handling, alterations or modifications in design or construction void this warranty. No sales personnel of the seller or any other person is authorized to make any warranties other than those described above, or to extend the duration of any warranties on behalf of Marshall Electronics, beyond the time period described above.

Due to constant effort to improve products and product features, specifications may change without notice.

Marshall

20608 Madrona Avenue, Torrance, CA 90503

Tel: (800) 800-6608 / (310) 333-0606 • Fax: 310-333-0688 *cont. on page 12*

www.marshall-usa.com

support@marshall-usa.com